





UNITED FIREFLO

Model F-06 Tools and Kits

Tools and Kits may be used on the United F-06, Mueller® Super Centurion™ and the U.S. Pipe Metroflow™/M-03 hydrants.

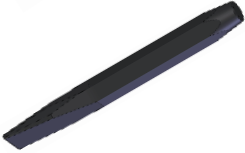
United Water Products carries a wide variety of tools and accessories to maintain and operate your United Fireflo F-06 Fire Hydrant.

TOOLS

| UNITED PART NO. | MUELLER PART NO. | DESCRIPTION | |
|-----------------|------------------|----------------------|---|
| F-06-311 | A-311 | Operating Wrench |  |
| F-06-317 | A-317 | Nozzle Lock Tool |  |
| F-06-359 | A-359 | Seat Removal Wrench |  |
| F-06-367 | A-367 | Brass Sleeve |  |
| F-06-316 | A-316 | 2-1/2" Nozzle Wrench |  |
| F-06-316 | A-316 | 4-1/2" Nozzle Wrench |  |



WARNING: This product can expose you to chemicals including lead, which is known to the State of California to cause cancer and birth defects or other reproductive harm. For more information go to www.P65Warnings.ca.gov.

SAFETY FLANGE REPAIR KIT

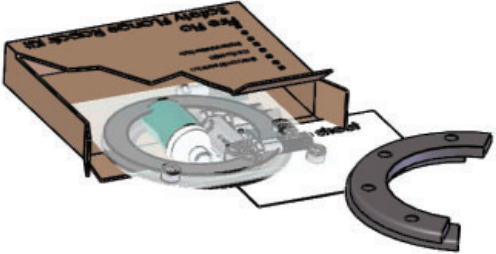
| UNITED PART NO. | MUELLER PART NO. | DESCRIPTION | |
|--|------------------|---|--|
| F-06-301 | A-301 | 5-1/4" Hydrant - Safety Flange Repair Kit |  |
| Consists of Part No's. F-06-25, F-06-26, F-06-27, F-06-28, F-06-29 & F-06-30 | | | |

5-1/4" HYDRANT EXTENSION KITS

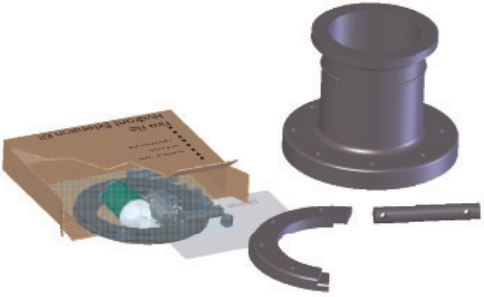
| UNITED PART NO. | MUELLER PART NO. | DESCRIPTION | |
|---|------------------|-------------------------|---|
| F-06-320-006 | A-320-006 | 6" Long "Extension Kit |  |
| F-06-320-010 | A-320-010 | 12" Long "Extension Kit | |
| F-06-320-016 | A-320-016 | 18" Long "Extension Kit | |
| F-06-320-020 | A-320-020 | 24" Long "Extension Kit | |
| F-06-320-026 | A-320-026 | 30" Long "Extension Kit | |
| F-06-320-030 | A-320-030 | 36" Long "Extension Kit | |
| F-06-320-036 | A-320-036 | 42" Long "Extension Kit | |
| F-06-320-040 | A-320-040 | 48" Long "Extension Kit | |
| Consists of Part No's. F-06-29, F-06-30, F-06-52, F-06-54, F-06-55, F-06-57 & F-06-53 | | | |

BONNET REPAIR KIT

| UNITED PART NO. | MUELLER PART NO. | DESCRIPTION | |
|---|------------------|----------------------------------|--|
| F-06-280-355 | 280355 | 5-1/4" Hydrant Bonnet Repair Kit |  |
| Consists of Part No's. F-06-3, F-06-5, F-06-6, F-06-10, F-06-12, F-06-51 & Weather Seal | | | |

SHOE REPAIR KIT

| UNITED PART NO. | MUELLER PART NO. | DESCRIPTION | |
|--------------------|-----------------------------|-----------------------------------|--|
| F-06-280-357 | 280357 (1996 or earlier) | 5-1/4" Hydrant Shoe Repair Kit |  |

Consists of Part No's. F-06-34, F-08-35, F-06-37, F-06-38, F-06-39, F-06-44, F-06-45, F-06-46, F-06-47, F-06-48 and F-06-51

MAIN VALVE REPAIR KIT

| UNITED PART NO. | MUELLER PART NO. | DESCRIPTION | |
|--------------------|-----------------------------|---|---|
| F-06-280-359 | 280359 (1996 or earlier) | 5-1/4" Hydrant Main Valve Repair Kit |  |

Consists of Part No's. F-06-39, F-08-43, F-06-44, F-06-45, F-06-46 and F-06-47

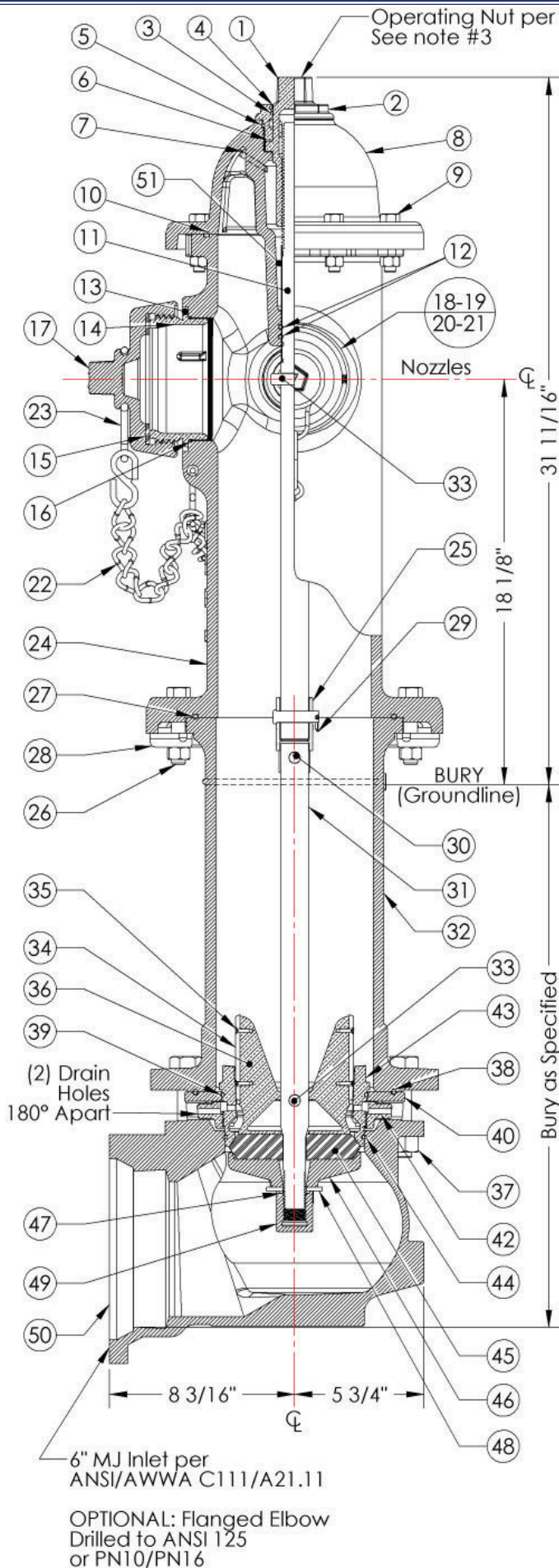

| Item No. | Description | Material | Specification | Qty. Req'd |
|----------|--------------------------------|--------------|--------------------|------------|
| 1 | Operating Nut | Bronze | ASTM B584 | 1 |
| 2 | Hold Down Nut | Bronze | ASTM B584 | 1 |
| 3 | Hold Down Nut O-Ring | Rubber | ASTM D2000, BUNA N | 1 |
| 4 | Weather Seal | Rubber | ASTM D2000, BUNA N | 1 |
| 5 | Bonnet O-Ring | Rubber | ASTM D2000, BUNA N | 1 |
| 6 | Anti-Friction Washer | Celcon | - | 1 |
| 7 | Oil Plug | Bronze | ASTM B16 | 1 |
| 8 | Bonnet | Cast Iron | ASTM A126, CL-B | 1 |
| 9 | Bonnet Bolts & Nuts | Steel | ZPS, A307 | 8 |
| 10 | Bonnet O-Ring | Rubber | ASTM D2000, BUNA N | 1 |
| 11 | Upper Rod | Steel | ASTM A576, Gr-B | 1 |
| 12 | Upper Rod O-Ring | Rubber | ASTM D2000, BUNA N | 2 |
| 13 | Nozzle Lock Key | Stn. Stl. | ASTM A276 | 6 |
| 14 | Pumper Nozzle | Bronze | ASTM B584 | 1 |
| 15 | Pumper Nozzle Gasket | Rubber | ASTM D2000, BUNA N | 1 |
| 16 | Pumper Nozzle O-Ring | Rubber | ASTM D2000, BUNA N | 1 |
| 17 | Pumper Nozzle Cap | Cast Iron | ASTM A126, CL-B | 1 |
| 18 | Hose Nozzle | Bronze | ASTM B584 | 2 |
| 19 | Hose Nozzle Gasket | Rubber | ASTM D2000, BUNA N | 2 |
| 20 | Hose Nozzle O-Ring | Rubber | ASTM D2000, BUNA N | 2 |
| 21 | Hose Nozzle Cap | Cast Iron | ASTM A126, CL-B | 2 |
| 22 | Cap Chain | Steel | Plated | 3 |
| 23 | Chain Ring | Steel | Plated | 3 |
| 24 | Standpipe Upper | Ductile Iron | ASTM A536 | 1 |
| 25 | Safety Coupling | Stn. Stl. | ASTM A890 | 1 |
| 26 | Safety Flange Bolts & Nuts | Steel | ZPS, A307 | 8 |
| 27 | Safety Flange O-Ring | Rubber | ASTM D2000, BUNA N | 1 |
| 28 | Safety Flange | Cast Iron | ASTM A126, CL-B | 2 |
| 29 | Cotter Pin | Stn. Stl. | ASTM A276 | 2 |
| 30 | Clevis Pin | Stn. Stl. | ASTM A276 | 2 |
| 31 | Lower Rod | Steel | ASTM A576 Gr-B | 1 |
| 32 | Standpipe Lower (Specify Bury) | Ductile Iron | ASTM A536 | 1 |
| 33 | Stem Pin | Stn. Stl. | ASTM A276 | 2 |
| 34 | Drain Valve Facing | HDPE | - | 2 |
| 35 | Drain Valve Screw | Stn. Stl. | ASTM A276 | 4 |
| 36 | Valve Top Plate | Bronze | ASTM B584 | 1 |
| 37 | Elbow & D.R.H. Bolts & Nuts | Stn. Stl. | SS304 | 6 |
| 38 | Drain Ring Housing O-Ring | Rubber | ASTM D2000, BUNA N | 1 |
| 39 | Seat Ring O-Ring (Top) | Rubber | ASTM D2000, BUNA N | 1 |
| 40 | Drain Ring Housing | Ductile Iron | ASTM A536 | 1 |
| 42 | Drain Ring | Bronze | ASTM B584 | 1 |
| 43 | Seat Ring | Bronze | ASTM B584 | 1 |
| 44 | Seat Ring O-Ring (Bottom) | Rubber | ASTM D2000, BUNA N | 1 |
| 45 | Main Valve | Rubber | ASTM D2000, BUNA N | 1 |
| 46 | Valve Bottom Plate | Ductile Iron | ASTM A536 | 1 |
| 47 | Cap Nut Seal | Rubber | ASTM D2000, BUNA N | 1 |
| 48 | Lock Washer | Stn. Stl. | ASTM A276 | 1 |
| 49 | Valve Bottom Plate Nut | Ductile Iron | ASTM A536 | 1 |
| 50 | Elbow | Ductile Iron | ASTM A536 | 1 |
| 51 | Lubricant (in Chamber) | Mineral Oil | Food Grade | 1 |

Notes:

- Part #'s 40, 46, 49 & 50 are Fusion Bonded Epoxy, inside and out, complying with AWWA C550.
- Pentagon measures 1-1/2" from point to flat at the base of the nut and 1-7/16" at the top; the height of the nut is to be 1" minimum.
- Pumper Outlet - Qty: 1 - Nominal size 4-1/2" with 4.5-4 NH threading per NFPA 1963.
- Hose Outlets - Qty: 2 pcs - Nominal size 2-1/2" with 2.5-7.5 NH threading per NFPA 1963.

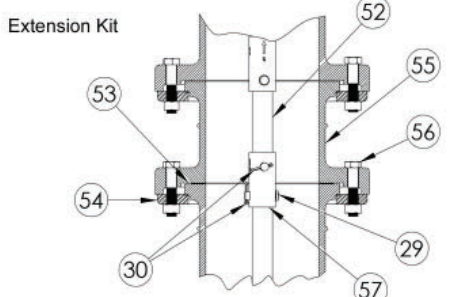

| Components of the Extension Kit | | | |
|---------------------------------|-----|---------------------------|-----|
| Clevis Pin | #29 | Extension Flange Coupling | #54 |
| Cotter Pin | #30 | Extension Standpipe | #55 |
| Extension Rod | #52 | Extension Bolts and Nuts | #56 |
| Extension Gasket | #53 | Extension Rod Coupling | #57 |